

**CABLE BONDING JUMPER:**

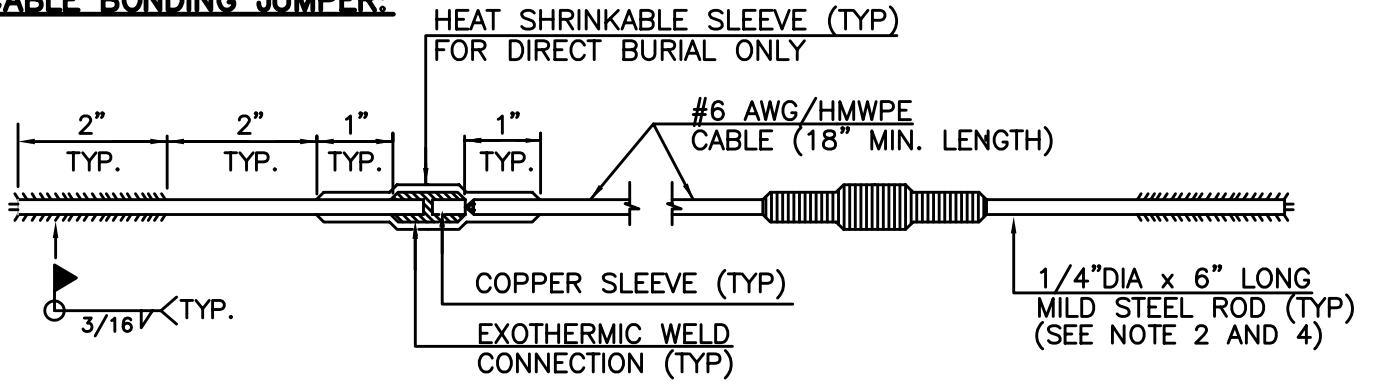

**BELL - SPIGOT ENDS:**

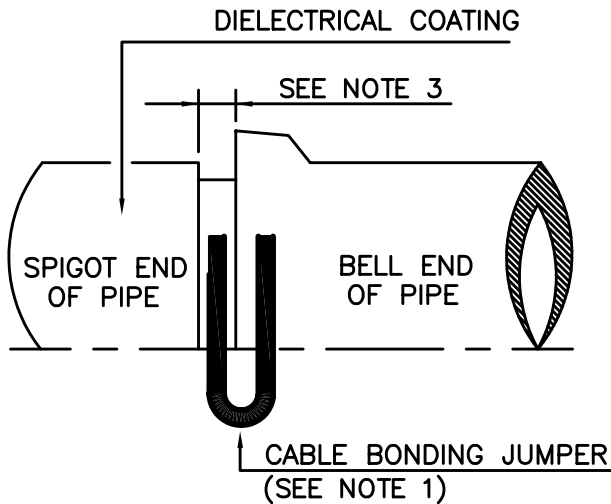

**RESTRAINED JOINTS:**

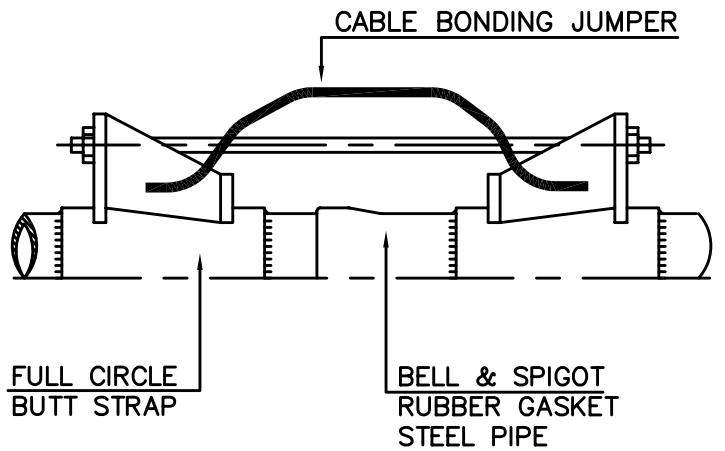

**FLEXIBLE FITTINGS AND FLANGED ENDS:**

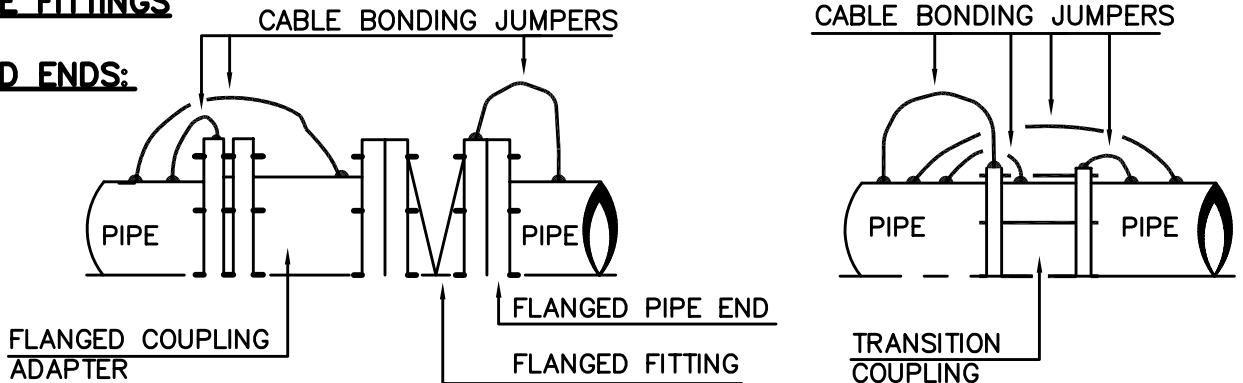

**NOTES:**

- 1) ONE CABLE BONDING JUMBER REQ'D PER JOINT
- 2) BEND ROD TO MATCH PIPE RADIUS.
- 3) PROVIDE SUFFICIENT DISTANCE BETWEEN WELDED ROD AND CONNECTION BELL TO ALLOW FOR MAXIMUM PIPE DEFLECTION.
- 4) WELD TO BARE STEEL.
- 5) EXPOSED STEEL WILL BE COATED WITH PRIMER AND WRAPPED WITH COAL TAR TAPE. #6 AWG/HMWPE CABLE SHOULD BE LEFT UNWRAPPED AND FREE TO MOVE.

NORTH MARIN WATER DISTRICT  
NOVATO, CALIFORNIA

**CABLE BONDING JUMPER INSTALLATION  
FOR BELL & SPIGOT STEEL PIPE & FITTINGS**

APPROVED	DATE	REV.	STD. NO.
	5\10\02	1	11

THIS STANDARD REPLACES NMWD STD-A-28